



C27 ACERT™ Diesel Oilfield Generator Set

725 ekW
60 Hz, 1800 rpm

PRIME

CAT® ENGINE SPECIFICATIONS



Image shown may not reflect actual engine configuration

V-12, 4-Stroke-Cycle water-cooled diesel

Bore	137.2 mm (5.41 in)
Stroke	152.4 mm (6 in)
Displacement	27 L (1648 in ³)
Compression Ratio.....	15:1
Aspiration	Turbocharged-Aftercooled
Fuel System.....	MEUI
Governor Type.....	ADEM™ A4
Package Weight.....	8799.7 kg (19,400 lbs)

FEATURES

Fuel/Emissions Strategy

- Configuration options for either best fuel economies or emissions reductions (non-certified, U.S. EPA Non-road Tier 2 levels) available to fit any application

Engine Design

- Rugged components for durability in harsh oilfield conditions
- Increased power density and rugged base for highly mobile jobs
- Permanent magnet, two-bearing, close coupled, oversized generator ideal for oilfield applications
- Heavy-duty, easy-to-clean cooling system with high ambient capability
- Advanced controls
- Focus on operator safety

Advanced Digital Engine Management

ADEM A4 control system providing integrated ignition, speed governing, protection, and controls. ADEM A4 has improved: user interface, display system, shutdown controls, and system diagnostics.

Cat® EMCP 4.2 Series Control Panels

- Integrated control system and communications gateway
- EMCP 4.2 is standard and offers basic engine/generator monitoring, metering and protection and an open protocol allowing for simple integration.
- Also features more advanced options including power metering, modbus capability, and programmable discreet output

Product Support Offered Through Global Cat Dealer Network

- More than 2,200 dealer outlets
- Cat factory-trained dealer technicians service every aspect of your petroleum engine
- Cat parts and labor warranty

Preventive maintenance agreements available for repair-before-failure options

S•O•SSM program matches your oil and coolant samples against Caterpillar set standards to determine:

- Internal engine component condition
- Presence of unwanted fluids
- Presence of combustion by-products
- Site-specific oil change interval

Over 80 Years of Engine Manufacturing Experience

Ownership of these manufacturing processes enables Caterpillar to produce high quality, dependable products.

- Cast engine blocks, heads, cylinder liners, and flywheel housings
- Machine critical components
- Assemble complete engine

Web Site

For all your petroleum power requirements, visit www.catoilandgas.cat.com.



C27 ACERT™ DIESEL OILFIELD GENERATOR SET

725 ekW – 60 Hz, 1800 rpm

STANDARD EQUIPMENT

Air Inlet System

Heavy-duty dual element canister-type air cleaner
Service indicator

Control Panels

EMCP 4.2
User interface panel — rear mount
Emergency stop pushbutton
Generator housing mounted

Cooling System

Radiator with guard sized for 50°C
Side-by-side cores
Metal top and bottom tanks
Coolant drain line with valve
Fan and belt guards
Cat Extended Life Coolant
Coolant level sensor

Exhaust System

Dry exhaust manifold

Fuel System

Primary fuel filter
Secondary fuel filter
Manual fuel priming pump
Fuel pump

Generators

Class H insulation
Permanent magnet
IP23 protection
Form wound stator

Anti-condensation space heaters
Two bearing
Close coupled
Oversized

Governor

ADEM™ A4

Lube System

Lubricating oil and filter
Oil cooler
Oil drain line with valves
Fumes disposal — left side
Gear-type lube oil pump

Mounting System

Heavy-duty oilfield welded steel base (skiddable)
Anti-vibration mounts (shipped loose)
Designed welded base for increased durability (I-beam design)
Dragability
Package lifting eyes

Starting/Charging System

24V starting motor(s)
24V, 45-amp charging alternator

General

Paint — Cat yellow except rails and radiators (gloss black)
SAE standard rotation
Flywheel and flywheel housing — SAE No. 0

OPTIONAL EQUIPMENT

Air Inlet System

Precleaners

Control System

Direct rack

Cooling System

Jacket water heater

Exhaust System

Flange and exhaust expanders
Exhaust shielding

Generators

Self excited

Mounting System

Short base — 187" (4750 mm) total length
Note: short base option does not include drag bars

Starting/Charging System

Air starting motor



C27 ACERT™ DIESEL OILFIELD GENERATOR SET

725 ekW – 60 Hz, 1800 rpm

SPECIFICATIONS

Cat SR4B Generator

Frame size 691, 693
 Excitation Permanent Magnet, SE Option
 Pitch..... 0.7143, 0.667
 Number of poles..... 4
 Number of bearings 2
 Number of leads 6
 Insulation UL 1446 Recognized Class H
 with tropicalization and antiabrasion
 IP Rating Drip Proof IP23
 Alignment Close Coupled

Cat EMCP 4.2 Series Control Panel

EMCP 4 controls
 Run/Auto/Stop control
 Speed adjust
 Voltage adjust
 Engine cycle crank
 Emergency stop pushbutton
 EMCP 4.2 controller
 24-volt DC operation
 Environmental sealed front face
 Text alarm/event descriptions
 True RMS AC metering, 3-phase, ±1% accuracy
 Digital indication for:
 rpm
 DC volts
 Operating hours
 Oil pressure (psi, kPa, or bar)
 Coolant temperature
 Volts (L-L and L-N), frequency (Hz)
 Amps (per phase and average)
 Power Factor (per phase and average)
 kW (per phase, average, and percent)
 kVA (per phase, average, and percent)

kVA (per phase, average, and percent)
 kW-hr (total)
 kVA-hr (total)
 Warning/shutdown with common LED indication
 of shutdowns for:
 Low oil pressure
 High coolant temperature
 Overspeed
 Emergency stop
 Failure to start (overcrank)
 Low coolant temperature
 Low coolant level
 Programmable protective relaying functions
 Generator phase sequence
 Over/Under voltage (27/59)
 Over/Under Frequency (81 o/u)
 Reverse Power (kW) (32)
 Reverse Reactive Power (kVA) (32RV)
 Overcurrent (50/51)
 Communications
 Customer data link (Modbus RTU)
 Accessory module data link
 Serial annunciator module data link
 6 programmable digital inputs
 4 programmable relay outputs (Form A)
 2 programmable relay outputs (Form C)
 2 programmable digital outputs
 Compatible with the following optional modules:
 Digital I/O module
 Local annunciator
 Remote CAN annunciator
 Remote serial annunciator
 RTD module
 Thermocouple module

C27 ACERT OILFIELD GENERATOR SET PACKAGES

	Drilling – 60 Hz	Production/Camp Power – 60 Hz
ekW Rating	725	725
kVA Rating	1035	907
rpm	1800	1800
Rated PF	0.7	0.8
Temperature Rise	80°C	105°C
Insulation Class	H	H
Overload	300%/10 sec	300%/10 sec
Excitation	PMG standard, SE option	PMG standard, SE option
Voltage	600	480
Voltage Regulator	Cat DVR	Cat DVR
Configuration	2-Brg	2-Brg
Coastal Protection	Yes	Yes
Space Heater	Yes	Yes
Construction	FW	FW
Frame Size	693	691
Available Configurations	Low BSFC, Low Emissions*	Low BSFC, Low Emissions*
BSFC – Fuel Economies Setting	0.328 lb/bhp-hr	0.328 lb/bhp-hr

*Non-certified Tier 2 levels



C27 ACERT™ DIESEL OILFIELD GENERATOR SET

725 ekW – 60 Hz, 1800 rpm

DIMENSIONS

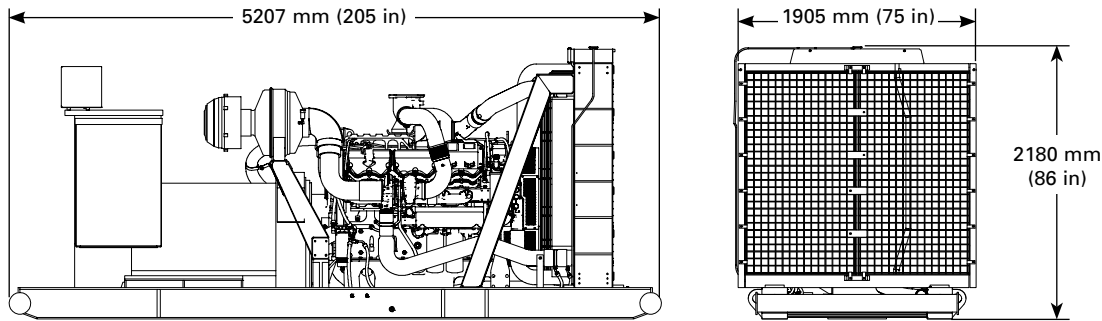

Package Dimensions		
Length	5207 mm	205 in
Length w/short base option	4750 mm	187 in
Width	1905 mm	75 in
Height	2180 mm	86 in
Engine Weight (dry)	8799.7 kg	19,400 lb

Note: For reference only — do not use for installation design.
See general dimension drawing #3716011 for detail.

RATING DEFINITIONS AND CONDITIONS

Meets or Exceeds International Specifications:
AS1359, CSA, IEC60034, ISO3046, ISO8528,
NEMA MG 1-33, UL508A, 98/37/EC.

Prime output available with varying load for an unlimited time. Average power output is 70% of the prime power rating. Typical peak demand is 100% of prime rated ekW with 10% overload capability for emergency use for a maximum of 1 hour in 12. Overload operation cannot exceed 25 hours per year. Prime power in accordance with ISO3046. Prime ambients shown indicate ambient temperature at 100% load which results in a coolant top tank temperature just below the alarm temperature.

Ratings are based on SAE J1349 standard conditions. These ratings also apply at ISO3046 standard conditions.

Fuel rates are based on fuel oil of 35° API [16°C (60°F)] gravity having an LHV of 42 780 kJ/kg (18,390 Btu/lb) when used at 29°C (85°F) and weighing 838.9 g/liter (7.001 lbs/U.S. gal). Additional ratings may be available for specific customer requirements, contact your Cat representative for details. For information regarding low sulfur fuel and biodiesel capability, please consult your Cat dealer.



From the library of Barrington Diesel Club

Materials and specifications are subject to change without notice. The International System of Units (SI) is used in this publication. CAT, CATERPILLAR, their respective logos, ACERT, ADEM, S•O•S, "Caterpillar Yellow" and the "Power Edge" trade dress, as well as corporate and product identity used herein, are trademarks of Caterpillar and may not be used without permission.