

# Detroit Diesel

## 149 ENGINE

### SPECIFICATIONS

*Bolt Torques, Firing Order, Adjust Valves, Adjust Injectors,  
Set Linkages and adjust Hydraulic Governor*



**Barrington Diesel Club**

<http://www.barringtondieselclub.co.za/>

# Detroit Diesel Industrial Model

# 8V-149TI 900 HP 800 HP

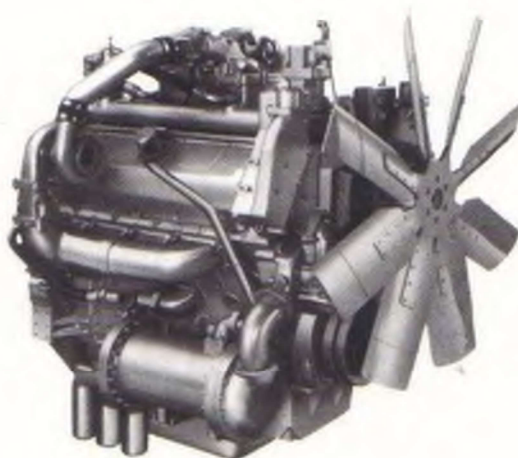

## Horsepower Rating

Basic Engine	8V-149TI
Injector	190
Rated Gross Power	900 BHP (671 kW) @ 1900 RPM
Peak Torque	2607 lb ft (3535 N-m) @ 1400 RPM
Injector	160
Rated Gross Power	800 BHP (597 kW) @ 1900 RPM
Peak Torque	2350 lb ft (3187 N-m) @ 1200 RPM

(Continuous Rating)

Injector	145
Gross Power	740 BHP (552 kW) @ 1900 RPM
Peak Torque	2157 lb ft (2925 N-m) @ 1400 RPM

Rated Fuel Consumption:

@ 900 BHP	.369 lbs/bhp-hr (224 g/kW-hr)
	46.7 gals/hr (176.8 L/hr)
@ 800 BHP	.366 lbs/bhp-hr (223 g/kW-hr)
	41.2 gals/hr (155.9 L/hr)

## Rating Explanation

RATED BHP is the power rating for variable speed and load applications where full power is required intermittently.

CONTINUOUS BHP is the power rating for applications operating under a constant load and speed for long periods of time.

FUEL CONSUMPTION CURVE shows fuel used in pounds per brake horsepower hour.

POWER OUTPUT guaranteed within 5% at standard ambient conditions.

THIS RATING does not include power requirements for accessory and standard equipment. For complete engine specifications for your particular requirements, see your distributor or authorized Detroit Diesel Allison representative.

† Rating conditions of SAE: 77°F (25°C) and 29.31 in Hg (99kPa) Barometer (Dry)

## Performance Curve †

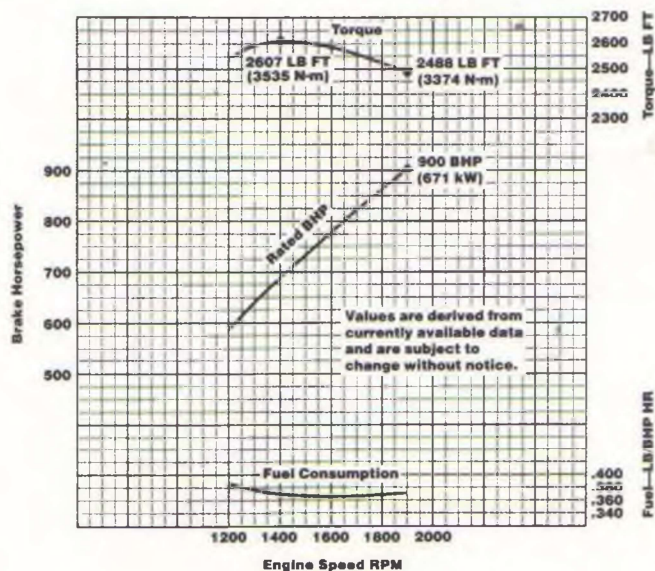

## General Specifications

Basic Engine . . . . .	8V-149TI
Model . . . . .	9083-7311
Number of Cylinders . . . . .	8
Bore and Stroke . . . . .	5.75 in × 5.75 in (146 mm × 146 mm)
Displacement . . . . .	1195 cu in (19.6 liters)
Engine Type . . . . .	Vee-2 cycle
Compression Ratio . . . . .	16 to 1
Length . . . . .	64 in (1625 mm)
Width . . . . .	64 in (1625 mm)
Height . . . . .	68 in (1727 mm)
Weight (dry) . . . . .	6000 lbs (2727 kg)
Engine Coolant Capacity . . . . .	91 qt (86.1 liters)
Total Engine Oil Capacity . . . . .	124 qt (117.3 liters)
<b>900 HP @ 1900 RPM:</b>	
Engine Heat Rej. . . . .	28,350 BTU/min (499 kW)
Exhaust Temperature . . . . .	745°F (396°C)
<b>800 HP @ 1900 RPM:</b>	
Engine Heat Rej. . . . .	25,200 BTU/min (443 kW)
Exhaust Temperature . . . . .	710°F (377°C)

Approximate dimensions shown. For complete dimensional information refer to installation drawing 2SA489. For complete coolant specifications, see publication 7SE298. For complete fuel and lubricating oil specifications, see publication 7SE270.

## Equipment Specifications

Alternator—24 volt, 65 amp
Blower—With bypass mechanism
Crankcase Pressure Monitor
Engine Oil Cooler—Tube and shell
Fan Bracket and Pulley Assembly Only
Flywheel—SAE #0
Flywheel Housing—SAE #0
Governor—Hydraulic
Intercooler
Oil Pan—Dual sump 15° angularity
Starter—24 volt
Turbocharger—Dual turbochargers, TV8401, 1.23 A/R

Additional options are also available. For a complete list, consult your authorized Detroit Diesel Allison representative.



## Detroit Diesel Allison

Division of General Motors

13400 Outer Drive, West, Detroit, Michigan 48239-4001  
(313/592-5000)

12V-149TI  
1350 hp

16V-149TI  
1800 hp

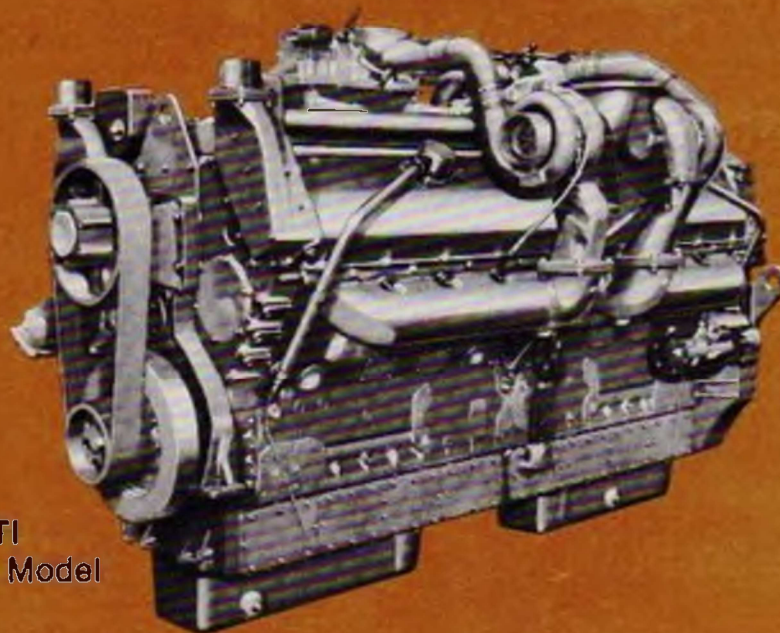

Typical 16V-149TI  
Fan-to-Flywheel Model

## specifications

Basic Engine	12V-149TI wlth 195 Injectors	16V-149TI with 195 Injectors
Model	9123-7301	9163-7301
Description	Turbocharged, Intercooled	Turbocharged, Intercooled
Number of Cylinders	12	16
Bore and Stroke	5.75 in x 5.75 in (146 mm x 146 mm)	5.75 in x 5.75 in (146 mm x 146 mm)
Displacement	1792 cu in (29.39 litres)	2389 cu in (39.18 litres)
Rated Power:* SAE: 85°F (29.4°C) and 29.00 in Hg (98.19kPa) Bar. (Dry)	1350 BHP (1007 kW) @ 1900 RPM	1800 BHP (1343 kW) @ 1900 RPM
Torque:* SAE: 85°F (29.4°C) and 29.00 in Hg (98.19 kPa) Bar. (Dry)	3840 lb ft (5206 N·m) @ 1600 RPM	5120 lb ft (6942 N·m) @ 1600 RPM
Compression Ratio	16 to 1	16 to 1
Approximate Dimensions:		
Length	91 in (2311 mm)	104 in (2642 mm)
Width	64 in (1626 mm)	64 in (1626 mm)
Height	69 in (1753 mm)	66 in (1676 mm)
Net Weight (dry)	9225 lbs (4184 kg)	10,865 lbs (4928 kg)

For complete dimensional information, refer to installation drawing 2SA274 for Model 9123-7301 and 2SA375 for Model 9163-7301

\*Preliminary - jacketwater intercooled

## Rating Explanation

RATED BHP is the power rating for variable speed and load applications where full power is required intermittently. Performance may be derated to improve fuel economy and extend engine life.

FUEL CONSUMPTION CURVE shows fuel used in pounds per brake horsepower hour.

THESE RATINGS do not include power losses for accessories and standard equipment.

PRELIMINARY ENGINE PERFORMANCE  
MODEL 12V-146TI WITH 195 INJECTORS

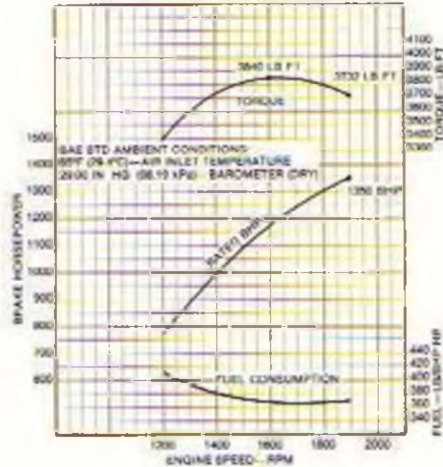

PRELIMINARY ENGINE PERFORMANCE  
MODEL 16V-146TI WITH 195 INJECTORS

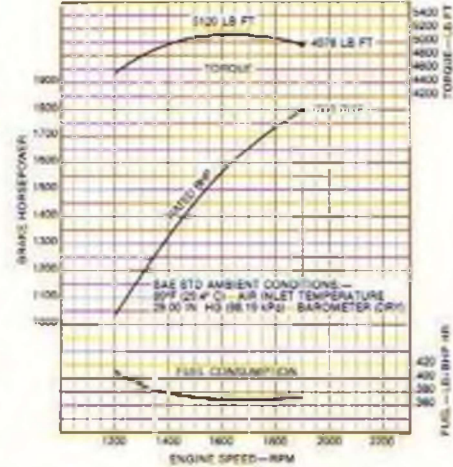

## standard equipment

**Air Inlet Housing**

**Alternator**—24 v, 65 amp

**Crankshaft Pulley**—Poly-Vee

**Engine Mounts**—Trunnion mounts

**Exhaust Manifold**

**Fan**—52", 8-blade, suction (Model 9123-7301);  
Fan bracket and pulley assembly only  
(Model 9163-7301)

**Flywheel**—SAE #0

**Flywheel Housing**—SAE #0, dual starter pads

**Fuel Filters**

**Governor**—Variable speed

**Injectors**—Cam operated, unit type  
needle valve

**Intercooler**

**Lube Oil Cooler**

**Lube Oil Filters**—Full flow, dual can

**Oil Pan**—Dual sump, for 15°  
inclination angle

**Starting Motors**—Two 24-volt

**Turbocharger**—Four turbos

**Vibration Damper**—Thick, heavy, viscous

For a complete listing of standard and optional equipment, consult your authorized Detroit Diesel Allison representative

Specifications subject to change without notice.



**Detroit Diesel Allison**  
Division of General Motors Corporation

13400 West Outer Drive Detroit, Michigan 48228

In Canada: Diesel Division, General Motors of Canada Limited, London, Ontario

# Detroit Diesel Engines

fan-to-flywheel  
models

12V-149  
800 hp

12V-149T  
1000 hp

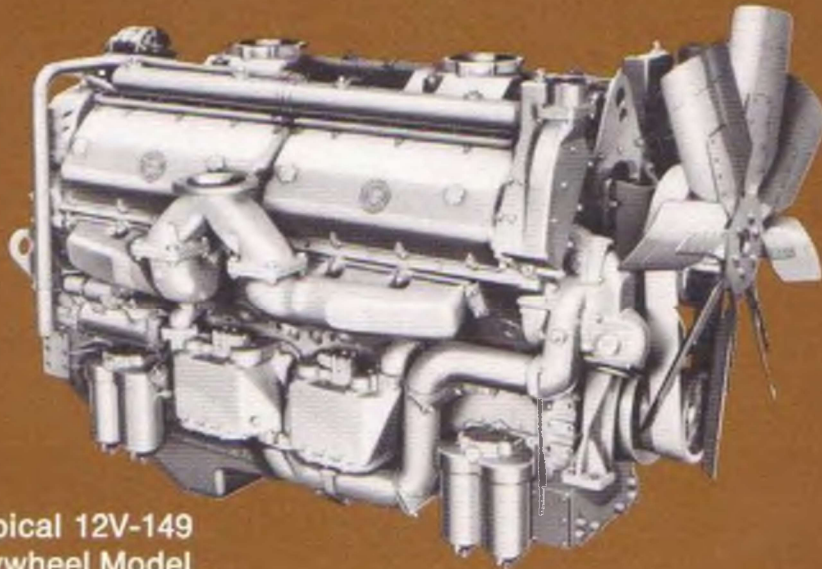

Typical 12V-149  
Fan-to-Flywheel Model

## specifications

Basic Engine	12V-149 130 Injectors	12V-149T 150 Injectors
Model	9123-7000	9123-7300
Engine Type	Two Cycle	Two Cycle
Number of Cylinders	12	12
Bore and Stroke	5.75 in x 5.75 in (146 mm x 146 mm)	5.75 in x 5.75 in (146 mm x 146 mm)
Two Cycle Displacement (Every Downstroke a Powerstroke)	1792 cu in (29.39 litres)	1792 cu in (29.39 litres)
Rated Power: SAE: 85°F (29.4°C) and 29.00 in Hg (98.19 kPa) Bar. (Dry)	800 BHP (597 kW) @ 1900 RPM	1000 BHP (746 kW) @ 1900 RPM
Continuous Power: SAE: 85°F (29.4°C) and 29.00 in Hg (98.19 kPa) Bar. (Dry)	675 BHP (504 kW) @ 1800 RPM	—————
Torque: SAE: 85°F (29.4°C) and 29.00 in Hg (98.19 kPa) Bar. (Dry)	2310 lbs ft (3132 N·m) @ 1500 RPM	2915 lbs ft (3952 N·m) @ 1500 RPM
Compression Ratio	17 to 1	17 to 1
Approximate Dimensions:		
Length	92 in (2337 mm)	91 in (2311 mm)
Width	57 in (1448 mm)	63 in (1600 mm)
Height	67 in (1702 mm)	69 in (1753 mm)
Net Weight (Mass) (dry)	8880 lbs (4028 kg)	9095 lbs (4125 kg)

For complete dimensional information, refer to installation drawing 2SA383 for Model 9123-7000 and 2SA362 for Model 9123-7300.

## Rating Explanation

**RATED BHP** is the power rating for variable speed and load application where full power is required intermittently. Performance may be derated to improve fuel economy and extend engine life.

**CONTINUOUS BHP** is the power rating for applications operating under a constant load and speed for long periods of time.

**FUEL CONSUMPTION CURVE** shows fuel used in pounds per brake horsepower hour.

**THESE RATINGS** do not include power requirements for accessory and standard equipment.

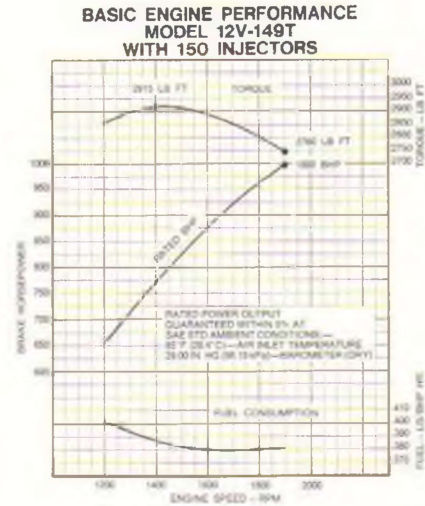
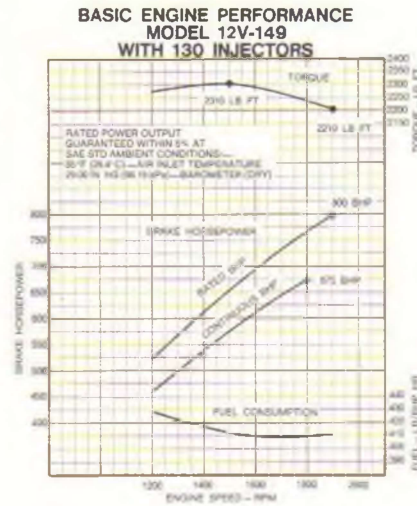

## standard equipment

### Air Inlet Housing

**Alternator**—24 volt, 65 amp

**Crankshaft Pulley**—Poly-Vee

**Engine Mounts**—Front trunnion

**Exhaust Manifold**—Vertical Center Outlet

**Fan**—48 in (1229 mm), 8 blades, suction, Model 9123-7000 only; 52 in (1331 mm), 8 blades, suction, Model 9123-7300 only

**Flywheel**—SAE #0

**Flywheel Housing**—SAE #0, dual starter pads

### Fuel Filters

**Governor**—Variable speed

**Injectors**—Cam operated, unit type, clean tip

**Lube Oil Cooler**

**Lube Oil Filter**—Full flow

**Oil Pan**—Stamped pan for 15° inclination angle, dual sump

**Starting Motor**—Two (2) 24 volt

**Turbocharger**—Model 9123-7300 only

For a complete listing of standard and optional equipment, consult your authorized Detroit Diesel Allison representative.

Specifications subject to change without notice.



**Detroit Diesel Allison**  
Division of General Motors Corporation

13400 West Outer Drive Detroit, Michigan 48228

In Canada: Diesel Division, General Motors of Canada Limited London Ontario

12V-149    16V-149  
805 hp    1070 hp

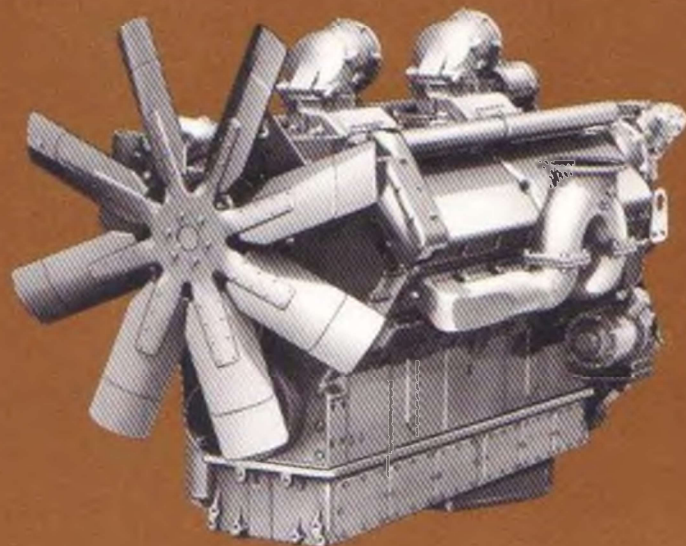

Typical 12V-149

## specifications

Basic Engine	12V-149 130 Injectors	16V-149 130 Injectors
Model	9123-7000	9163-7000
Description	Naturally Aspirated	Naturally Aspirated
Number of Cylinders	12	16
Bore and Stroke	5.75 in × 5.75 in (146 mm × 146 mm)	5.75 in × 5.75 in (146 mm × 146 mm)
Displacement	1792 cu in (29.39 liters)	2389 cu in (39.18 liters)
Rated Gross Power: SAE: 77 °F (25 °C) and 29.31 in Hg (99 kPa) Barometer (Dry)	805 BHP (601 kW) @ 1900 RPM	1070 BHP (798 kW) @ 1900 RPM
Continuous Gross Power: SAE: 77 °F (25 °C) and 29.31 in Hg (99 kPa) Barometer (Dry)	675 BHP (504 kW) @ 1800 RPM	900 BHP (671 kW) @ 1800 RPM
Torque: SAE: 77 °F (25 °C) and 29.31 in Hg (99 kPa) Barometer (Dry)	2326 lb ft (3154 N•m) @ 1400 RPM	3106 lb ft (4212 N•m) @ 1400 RPM
Compression Ratio	17 to 1	17 to 1
Approximate Dimensions:		
Length	93 in (2362 mm)	110 in (2794 mm)
Width	59 in (1499 mm)	54 in (1372 mm)
Height	61 in (1549 mm)	60 in (1524 mm)
Net Weight (Dry)	8490 lbs (3851 kg)	10,490 lbs (4758 kg)

For complete dimensional information, refer to installation drawing 2SA363 for Model 9123-7000, and 2SA360 for Model 9163-7000.

## Rating Explanation

**RATED BHP** is the power rating for variable speed and load applications where full power is required intermittently.

**CONTINUOUS BHP** is the power rating for applications operating under a constant load and speed for long periods of time.

**FUEL CONSUMPTION CURVE** shows fuel used in pounds per brake horsepower hour.

**POWER OUTPUT** guaranteed within 5% at standard ambient conditions.

**THIS RATING** does not include power requirements for accessory and standard equipment.

For complete engine specifications for your particular requirements, see your distributor or authorized Detroit Diesel Allison representative.

†Rating conditions of SAE: 77°F (25°C) and 29.31 in Hg (99 kPa) Barometer (Dry)

**BASIC ENGINE PERFORMANCE  
MODEL 12V-149 WITH 130 INJECTORS†**

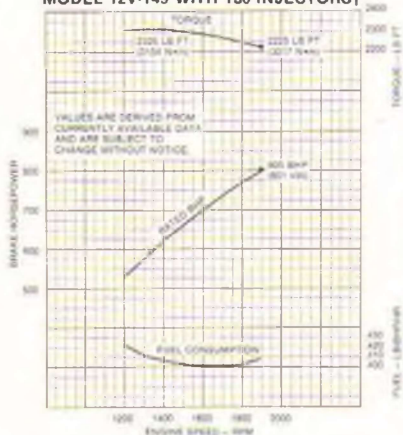

**BASIC ENGINE PERFORMANCE  
MODEL 16V-149 WITH 130 INJECTORS†**

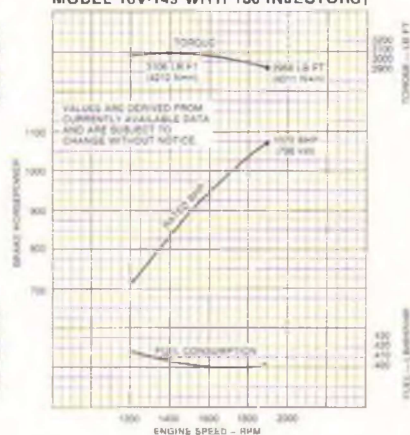

## standard equipment

**Air Box Drain Tubes**

**Air Inlet Housing**

**Alternator**—24 volt, 65 amp

**Crankshaft Pulley**—Poly-Vee

**Engine Mounts**—Front trunnion

**Exhaust Manifold**

**Fan**—48 in (1229 mm), 8 blades, right-hand suction, 12V-149; 52 in (1331 mm), 8 blades, right-hand suction, 16V-149

**Flywheel**—SAE #0

**Flywheel Housing**—SAE #0

**Fuel Filters**

**Governor**—Variable speed

**Injectors**—Cam operated, unit type, clean tip

**Lube Oil Cooler**—Plate type

**Lube Oil Filters**—Full flow, spin on

**Oil Pan**—Stamped steel, dual sump, for 15° inclination angle

**Starting Motor**—Two (2) 24 volt

**Vibration Damper**—Thick, heavy, viscous

For a complete listing of standard and optional equipment, consult your authorized Detroit Diesel Allison representative.

### WORLDWIDE REGIONAL OFFICES

Atlanta, Georgia  
(404/257-3630)  
Naperville, Illinois  
(312/961-6750)

Dallas, Texas  
(214/659-5050)

Detroit, Michigan  
(313/556-5800)

Parsippany, New Jersey  
(201/993-4040)

Fremont, California  
(415/498-5200)

London, Ontario, Canada  
(519/452-5000)

Rotterdam, The Netherlands  
(31) 10-29-0000

Dandenong, Victoria, Australia  
(61) 3-797-7911

Athens, Greece  
(30) 1-6833-100

Coral Gables, Florida  
(305/446-4900)

Jurong Town, Singapore  
(65) 265-4697

Mexico City, Mexico  
(905) 250-4354

## Detroit Diesel Allison

Division of General Motors

13400 Outer Drive, West, Detroit, Michigan 48239-4001  
(313/592-5000)

### OFFICES

Denver, Colorado, U.S.A.  
Los Angeles, California, U.S.A.  
Arlington, Virginia, U.S.A.  
Antwerp, Belgium  
Biel Bienne, Switzerland  
Helsinki, Finland  
Lisbon, Portugal

Oslo, Norway  
Paris, France  
Ruesselsheim, Germany  
Stockholm, Sweden  
Northampton, England  
Johannesburg, South Africa  
Nairobi, Kenya

Adelaide, Australia  
Brisbane, Australia  
Sydney, Australia  
West Perth, Australia  
Jakarta, Indonesia  
Taipei, Taiwan  
Tokyo, Japan  
Beijing, China  
Bogota, Colombia  
Buenos Aires, Argentina  
Lima, Peru  
Santiago, Chile  
Sao Paulo, Brasil

# Detroit Diesel Engines

fan-to-flywheel  
models

12V-149TI  
1350 hp

16V-149TI  
1800 hp

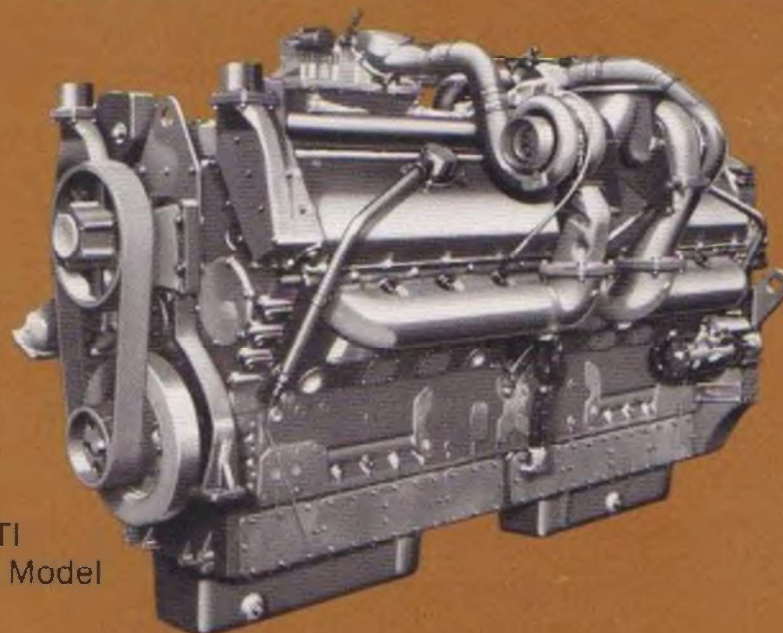

Typical 16V-149TI  
Fan-to-Flywheel Model

## specifications

Basic Engine	12V-149TI with 195 Injectors	16V-149TI with 195 Injectors
Model	9123-7301	9163-7301
Description	Turbocharged, Intercooled	Turbocharged, Intercooled
Number of Cylinders	12	16
Bore and Stroke	5.75 in x 5.75 in (146 mm x 146 mm)	5.75 in x 5.75 in (146 mm x 146 mm)
Displacement	1792 cu in (29.39 litres)	2389 cu in (39.18 litres)
Rated Power:*		
SAE: 85°F (29.4°C) and 29.00 in Hg (98.19kPa) Bar. (Dry)	1350 BHP (1007 kW) @ 1900 RPM	1800 BHP (1343 kW) @ 1900 RPM
Torque:*		
SAE: 85°F (29.4°C) and 29.00 in Hg (98.19 kPa) Bar. (Dry)	3840 lb ft (5206 N·m) @ 1600 RPM	5120 lb ft (6942 N·m) @ 1600 RPM
Compression Ratio	16 to 1	16 to 1
Approximate Dimensions:		
Length	91 in (2311 mm)	104 in (2642 mm)
Width	64 in (1626 mm)	64 in (1626 mm)
Height	69 in (1753 mm)	66 in (1676 mm)
Net Weight (dry)	9225 lbs (4184 kg)	10,865 lbs (4928 kg)

For complete dimensional information, refer to installation drawing 2SA374 for Model 9123-7301 and 2SA375 for Model 9163-7301

\*Preliminary - jacketwater intercooled

## Rating Explanation

RATED BHP is the power rating for variable speed and load applications where full power is required intermittently. Performance may be derated to improve fuel economy and extend engine life.

FUEL CONSUMPTION CURVE shows fuel used in pounds per brake horsepower hour.

THESE RATINGS do not include power losses for accessories and standard equipment.

PRELIMINARY ENGINE PERFORMANCE  
MODEL 12V-149T1 WITH 195 INJECTORS

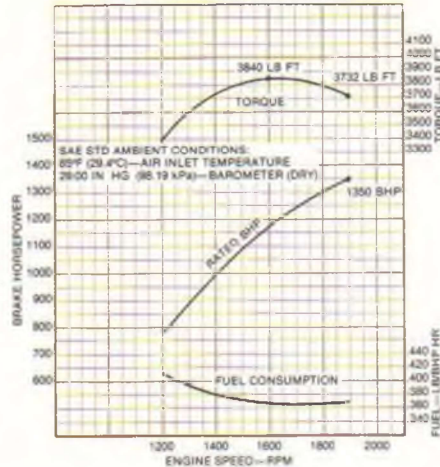

PRELIMINARY ENGINE PERFORMANCE  
MODEL 16V-149T1 WITH 195 INJECTORS

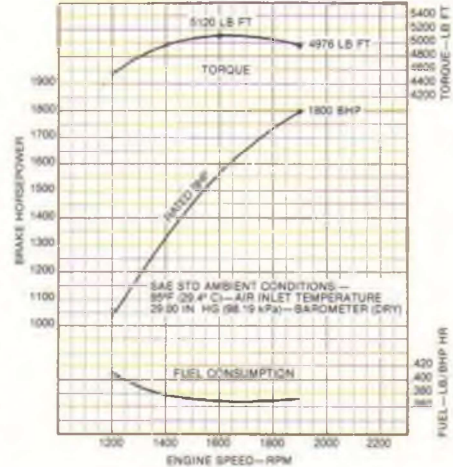

## standard equipment

**Air Inlet Housing**

**Alternator**—24 v, 65 amp

**Crankshaft Pulley**—Poly-Vee

**Engine Mounts**—Trunnion mounts

**Exhaust Manifold**

**Fan**—52", 8-blade, suction (Model 9123-7301);  
Fan bracket and pulley assembly only  
(Model 9163-7301)

**Flywheel**—SAE #0

**Flywheel Housing**—SAE #0, dual starter pads

**Fuel Filters**

**Governor**—Variable speed

**Injectors**—Cam operated, unit type  
needle valve

**Intercooler**

**Lube Oil Cooler**

**Lube Oil Filters**—Full flow, dual can

**Oil Pan**—Dual sump, for 15°  
inclination angle

**Starting Motors**—Two 24-volt

**Turbocharger**—Four turbos

**Vibration Damper**—Thick, heavy, viscous

For a complete listing of standard and optional equipment, consult your authorized Detroit Diesel Allison representative

Specifications subject to change without notice.



**Detroit Diesel Allison**  
Division of General Motors Corporation

13400 West Outer Drive Detroit, Michigan 48228

In Canada: Diesel Division, General Motors of Canada Limited, London Ontario

# Detroit Diesel Engines

## fan-to-flywheel models

12V-149	12V-149T	12V-149TI	12V-149TI	16V-149	16V-149T	16V-149TI	16V-149TI
805 hp	1050 hp	1200 hp	1350 hp	1070 hp	1400 hp	1600 hp	1800 hp

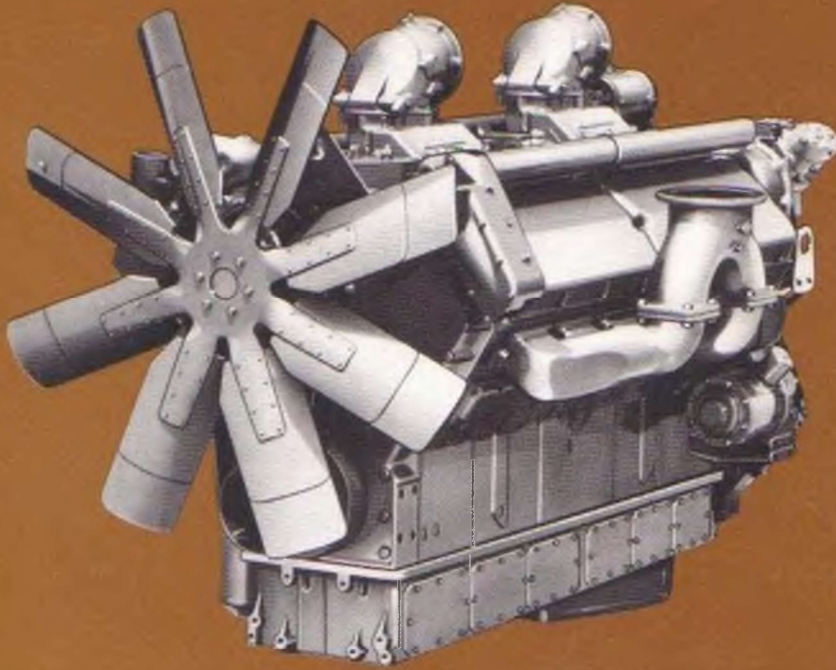

Typical 12V-149  
Fan-To-Flywheel Model

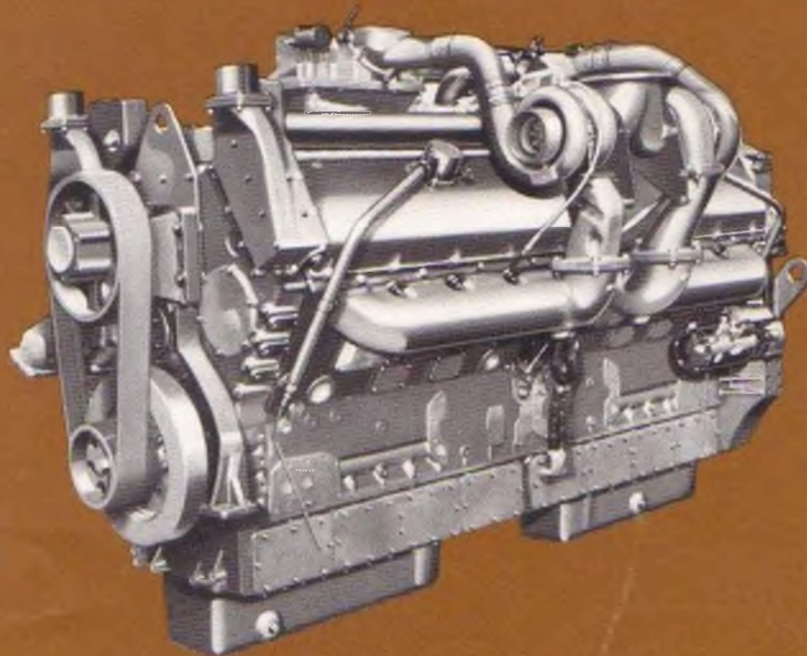

Typical 16V-149TI  
Fan-To-Flywheel Model

Basic Engine	12V-149 130 Injectors	12V-149T 145 Injectors	12V-149TI 160 Injectors	12V-149TI 190 Injectors
Model	9123-7000	9123-7300	9123-7301	9123-7311
Description	Naturally Aspirated	Turbocharged	Turbocharged Intercooled	Turbocharged Intercooled
Number of Cylinders	12	12	12	12
Bore and Stroke	5.75 in × 5.75 in (146 mm × 146 mm)	5.75 in × 5.75 in (146 mm × 146 mm)	5.75 in × 5.75 in (146 mm × 146 mm)	5.75 in × 5.75 in (146 mm × 146 mm)
Displacement	1792 cu in (29.39 liters)	1792 cu in (29.39 liters)	1792 cu in (29.39 liters)	1792 cu in (29.39 liters)
Rated Gross Power: SAE: 77 °F (25 °C) and 29.31 in Hg (99 kPa) Barometer (Dry)	805 BHP (601 kW) @ 1900 RPM	1050 BHP (783 kW) @ 1900 RPM	1200 BHP (895 kW) @ 1900 RPM	1350 BHP (1007 kW) @ 1900 RPM
Continuous Gross Power: SAE: 77 °F (25 °C) and 29.31 in Hg (99 kPa) Barometer (Dry)	675 BHP (504 kW) @ 1800 RPM	675 BHP (504 kW) @ 1800 RPM	810 BHP (604 kW) @ 1800 RPM	810 BHP (604 kW) @ 1800 RPM
Torque: SAE: 77 °F (25 °C) and 29.31 in Hg (99 kPa) Barometer (Dry)	2326 lb ft (3154 N•m) @ 1400 RPM	3116 lb ft (4225 N•m) @ 1200 RPM	3480 lb ft (4719 N•m) @ 1200 RPM	3909 lb ft (5301 N•m) @ 1400 RPM
Compression Ratio	17 to 1	17 to 1	16 to 1	16 to 1
Approximate Dimensions:				
Length	93 in (2362 mm)	93 in (2362 mm)	93 in (2362 mm)	93 in (2362 mm)
Width	59 in (1499 mm)	62 in (1575 mm)	62 in (1575 mm)	62 in (1575 mm)
Height	61 in (1549 mm)	68 in (1727 mm)	70 in (1778 mm)	70 in (1778 mm)
Net Weight (Dry)	8490 lbs (3851 kg)	9030 lbs (4096 kg)	9110 lbs (4132 kg)	9110 lbs (4132 kg)

For complete dimensional information, refer to installation drawing 2SA363 for Model 9123-7000, 2SA490 for Model 9123-7300, 2SA491 for Model 9123-7301 and 2SA492 for Model 9123-7311.

### Rating Explanation

RATED BHP is the power rating for variable speed and load applications where full power is required intermittently.  
 CONTINUOUS BHP is the power rating for applications operating under a constant load and speed for long period of time.  
 For complete engine specifications for your particular requirements, see your distributor or authorized Detroit Diesel Allison representative.

**BASIC ENGINE PERFORMANCE  
MODEL 12V-149 WITH 130 INJECTORS†**

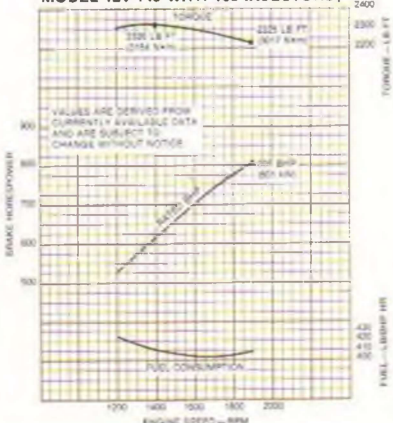

**BASIC ENGINE PERFORMANCE  
MODEL 12V-149T WITH 145 INJECTORS†**

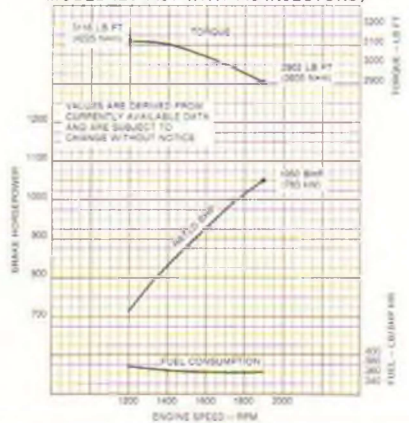

**BASIC ENGINE PERFORMANCE  
MODEL 12V-149TI†**

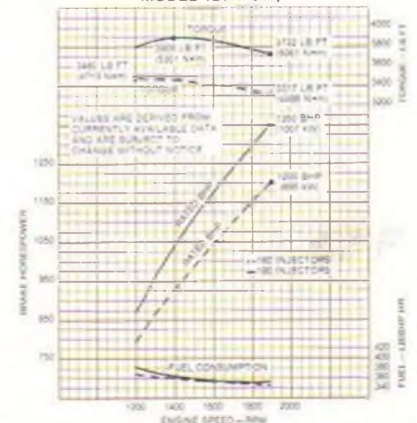

# specifications

16V-149 130 Injectors	16V-149T 145 Injectors	16V-149TI 160 Injectors	16V-149TI 190 Injectors
9163-7000	9163-7300	9163-7301	9163-7311
Naturally Aspirated	Turbocharged	Turbocharged Intercooled	Turbocharged Intercooled
16	16	16	16
5.75 in × 5.75 in (146 mm × 146 mm)	5.75 in × 5.75 in (146 mm × 146 mm)	5.75 in × 5.75 in (146 mm × 146 mm)	5.75 in × 5.75 in (146 mm × 146 mm)
2389 cu in (39.18 liters)	2389 cu in (39.18 liters)	2389 cu in (39.18 liters)	2389 cu in (39.18 liters)
1070 BHP (798 kW) @ 1900 RPM	1400 BHP (1044 kW) @ 1900 RPM	1600 BHP (1194 kW) @ 1900 RPM	1800 BHP (1343 kW) @ 1900 RPM
900 BHP (671 kW) @ 1800 RPM	900 BHP (671 kW) @ 1800 RPM	1080 BHP (806 kW) @ 1800 RPM	1080 BHP (806 kW) @ 1800 RPM
3106 lb ft (4212 N•m) @ 1400 RPM	4213 lb ft (5713 N•m) @ 1400 RPM	4689 lb ft (6358 N•m) @ 1400 RPM	5290 lb ft (7173 N•m) @ 1400 RPM
17 to 1	17 to 1	16 to 1	16 to 1
110 in (2794 mm) 54 in (1372 mm) 60 in (1524 mm) 10,490 lbs (4758 kg)	106 in (2692 mm) 64 in (1626 mm) 67 in (1702 mm) 10,690 lbs (4849 kg)	106 in (2692 mm) 64 in (1626 mm) 68 in (1727 mm) 11,210 lbs (5085 kg)	106 in (2692 mm) 64 in (1626 mm) 68 in (1727 mm) 11,210 lbs (5085 kg)

†123-7311, 2SA360 for Model 9163-7000, 2SA492 for Model 9163-7300, and 2SA493 for Model 9163-7301 and Model 9163-7311.

FUEL CONSUMPTION CURVE shows fuel used in pounds per brake horsepower hour. THESE RATINGS do not include power requirements for accessory and standard equipment.  
†Rating conditions of SAE: 77°F (25°C) and 29.31 in Hg (99 kPa) Barometer (Dry)

## performance

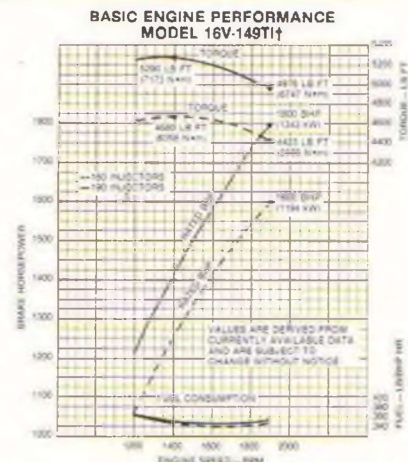
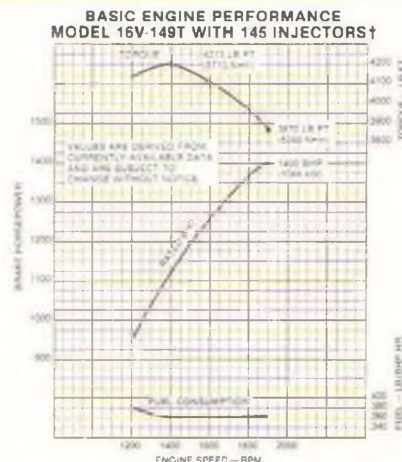
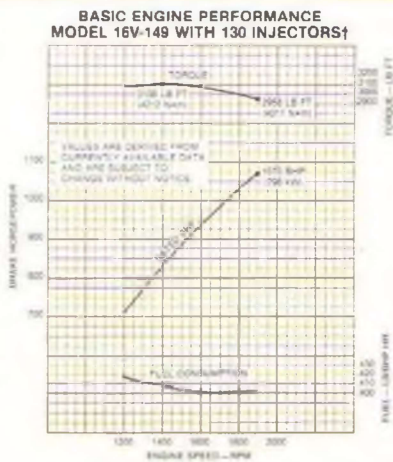

# standard equipment

## Air Box Drain Tubes

## Air Inlet Housing

Alternator—24 volt, 65 amp

Crankshaft Pulley—Poly-Vee

Engine Mounts—Front trunnion

## Exhaust Manifold

Fan—48 in (1229 mm), 8 blades, right-hand suction, 12V-149 only; 52 in (1331 mm), 8 blades, right-hand suction, 12V-149T, 12V-149TI, & 16V-149 only; fan bracket and pulley assembly, 16V-149T & 16V-149TI only

Flywheel—SAE #0

Flywheel Housing—SAE #0

## Fuel Filters

Governor—Variable speed

Injectors—Cam operated, unit type, clean tip

Intercooler—12V-149TI & 16V-149TI only

Lube Oil Cooler

Lube Oil Filters—Full flow

Oil Pan—Stamped steel, dual sump, for 15° inclination angle

Starting Motor—Two (2) 24 volt

Turbocharger—12V-149T, 12V-149TI, 16V-149T, & 16V-149TI only

Vibration Damper—Thick, heavy, viscous

For a complete listing of standard and optional equipment, consult your authorized Detroit Diesel Allison representative.

Information and specifications subject to change without notice or obligation.

### WORLDWIDE REGIONAL OFFICES

Atlanta, Georgia  
(404/257-3630)

Naperville, Illinois  
(312/961-6750)

Dallas, Texas  
(214/659-5050)

Detroit, Michigan  
(313/556-5800)

Parsippany, New Jersey  
(201/993-4040)



## Detroit Diesel Allison

Division of General Motors

13400 Outer Drive, West, Detroit, Michigan 48239-4001  
(313/592-5000)

Fremont, California  
(415/498-5200)

London, Ontario, Canada  
(519/452-5000)

Rotterdam, The Netherlands  
(31) 10-29-0000

Dandenong, Victoria, Australia  
(61) 3-797-7911

Athens, Greece  
(30) 1-770-6669

Coral Gables, Florida  
(305/446-4900)

Jurong Town, Singapore  
(65) 265-4697

Mexico City, Mexico  
(905) 250-4354

**OFFICES**  
Denver, Colorado, U.S.A.  
Los Angeles, California, U.S.A.

Antwerp, Belgium  
Biel Bienne, Switzerland  
Helsinki, Finland  
Lisbon, Portugal  
Oslo, Norway  
Paris, France

Ruesselsheim, Germany  
Stockholm, Sweden

Northampton, England  
Johannesburg, South Africa  
Nairobi, Kenya  
Adelaide, Australia  
Brisbane, Australia  
Sydney, Australia  
West Perth, Australia  
Jakarta, Indonesia  
Taipei, Taiwan  
Tokyo, Japan  
Bogota, Colombia  
Buenos Aires, Argentina  
Lima, Peru  
Santiago, Chile  
Sao Paulo, Brasil