

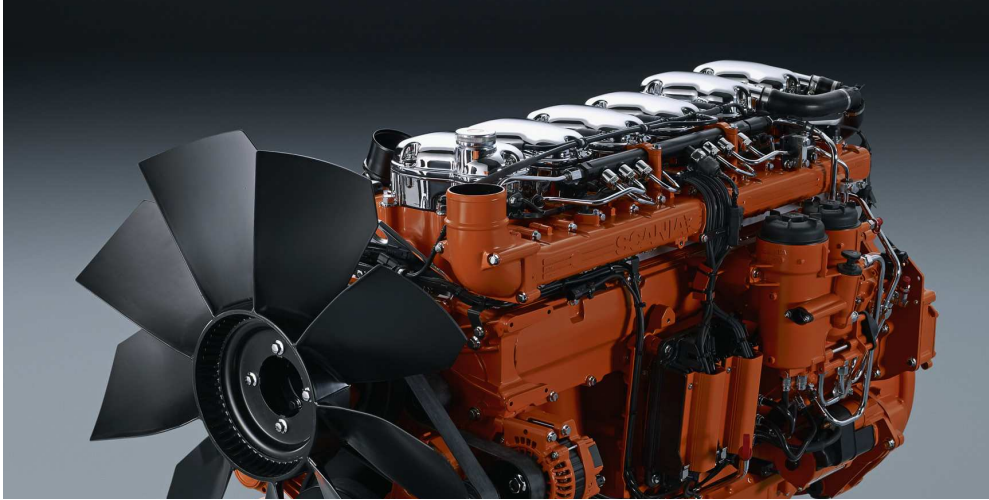

DC13 078A. 264 kW (360 hp)

EU Stage IIIB



The industrial engines from Scania are based on a robust design with a strength optimised cylinder block containing wet cylinder liners that can easily be exchanged. Individual cylinder heads with 4 valves per cylinder promotes repairability and fuel economy.

The engine is equipped with a Scania developed Engine Management System, EMS, in order to ensure the control of all aspects related to engine performance. The injection system is Scania's XPI (Extra High Pressure Injection), a common rail system that in combination with SCR (Selective Catalytic Reduction) gives low exhaust emissions with good fuel economy and a high torque. The engine can be fitted with many accessories such as air cleaners, silencers, PTOs and flywheels in order to suit a variety of installations.

	Rating	Engine speed (rpm)		
		1200	1500	1800
Gross power (kW)	ICFN	191	231	264
Gross power (hp, metric)	ICFN	260	314	360
Gross torque (Nm)	ICFN	1521	1471	1403
Spec fuel consumption. Full load (g/kWh)		183	186	200
Spec fuel consumption. 3/4 load (g/kWh)		185	187	199
Spec fuel consumption. 1/2 load (g/kWh)		193	198	210
Reductant consumption. Full load (g/kWh)		20	17	12
Heat rejection to cooling water (kW)		76	78	89

ICFN – Continuous service: Rated output available 1/1 h.
Unlimited h/year service time at a load factor of 100%

Standard equipment

- Scania Engine Management System, EMS
- Extra high pressure fuel injection system, XPI
- Turbocharger
- Fuel filter and extra pre-filter with water separator
- Fuel heater
- Oil filter, full flow
- Centrifugal oil cleaner
- Oil cooler, integrated in block
- Oil filler, in valve cover
- Deep front oil sump
- Oil dipstick, in block
- Magnetic drain plug for oil draining
- Starter, 1-pole 6.0 kW
- Alternator, 1-pole 100A
- Flywheel, for use with friction clutch
- Silumin flywheel housing, SAE 1 flange
- Front-mounted engine brackets
- SCR system
- Open crankcase ventilation
- Operator's manual

Optional equipment

- Cooling package
- Puller and pusher fans
- Fan ring with sealing
- Hydraulic pump
- Air compressor
- AC compressor
- Side-mounted PTO
- Front-mounted PTO
- Exhaust connections
- Electrical base system
- Control and instrument panels
- Accelerator position sensor
- Engine heater
- Flywheels: SAE11.5", SAE14", DANA15/16", ZF WG260
- Stiff rubber engine suspension
- Air cleaner
- Closed crankcase ventilation
- Studs in flywheel housing
- External thermostat for extra oil cooler
- Low coolant level reaction
- Variable idle speed setting
- Low oil sump
- Oil level sensor



DC13 078A. 264 kW (360 hp)

EU Stage IIIB

Engine description

No of cylinders	6 in-line
Working principle	4-stroke
Firing order	1 - 5 - 3 - 6 - 2 - 4
Displacement	12.7 litres
Bore x stroke	130 x 160 mm
Compression ratio	17.3:1
Weight	1050 kg (excl oil and coolant)
Piston speed at 1500 rpm	8.0 m/s
Piston speed at 1800 rpm	9.6 m/s
Camshaft	High position alloy steel
Pistons	Steel pistons
Connection rods	I-section press forgings of alloy steel
Crankshaft	Alloy steel with hardened and polished bearing surfaces
Oil capacity	34-45 dm ³
Electrical system	1-pole 24V

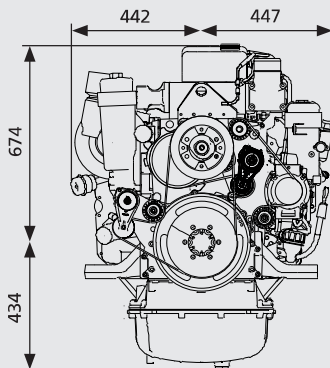
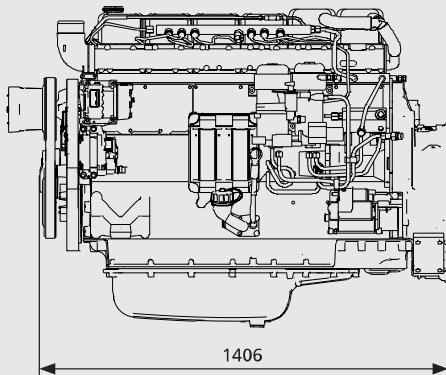

All dimensions in mm

Output

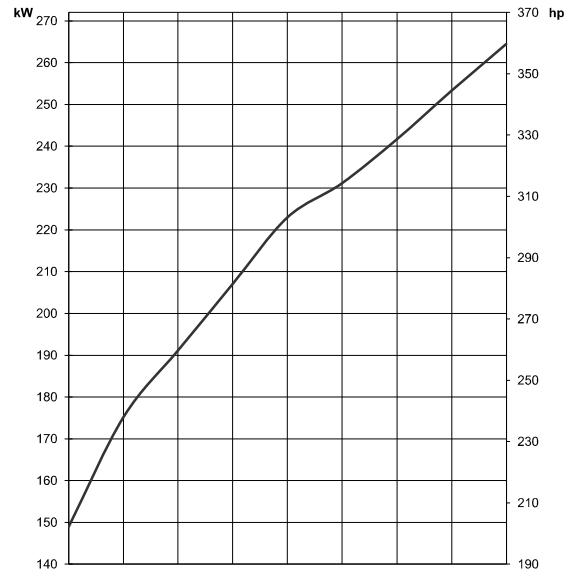

Torque

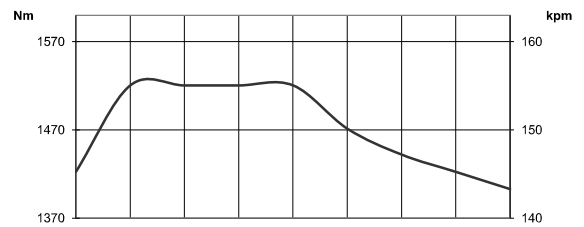

Spec fuel and Reductant consumption

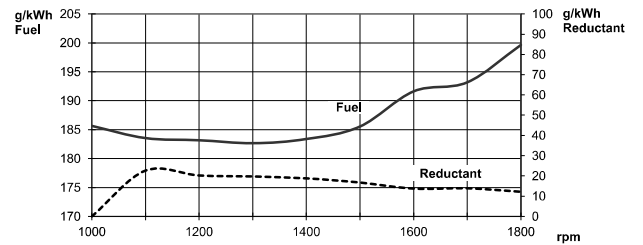

Test conditions Air temperature +25°C. Barometric pressure 100 kPa (750 mmHg). Humidity 30%. Diesel fuel acc. to ECE R 24 Annex 6, Density of fuel 0.840 kg/dm³, Viscosity of fuel 3.0 cSt at 40°C, Energy value 42700 kJ/kg. Power test code ISO 3046. Power and fuel values +/-3%.



SCANIA

SE 151 87 Södertälje, Sweden
 Telephone +46 8 553 810 00
 Telefax +46 8 553 829 93
 www.scania.com
 engines@scania.com



SCR system

US Tier 4i, EU Stage IIIB

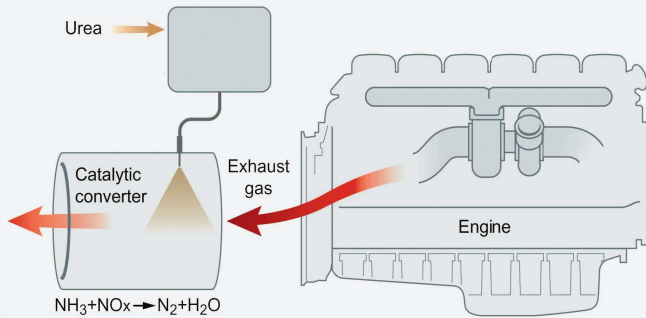

The principle for Scania SCR system

SCR (Selective Catalytic Reduction) technology is used on Scania's engines for Stage IIIB and Tier 4i to reduce the NO_x content in the exhaust gases. A chemical process is started by injecting reductant, a urea and water mixture, into the exhaust gas stream. During injection the water evaporates and the urea breaks down to form ammonia. The ammonia then reacts with the nitrogen gases in the catalytic converter and forms harmless products such as nitrogen gas and water. Through the use of SCR the exhaust gases are purged of poisonous levels of NO_x in the best possible way. Scania is making use of a system that is carefully developed and tested in our own laboratory.

The reductant tank holds 38 or 60 litres and is heated by the engine's cooling system in order to avoid freezing of the urea solution, urea freezes at -11°C. The reductant tank and a pump module are delivered as a unit which is fitted to brackets for an easy installation. The Scania system contains all mechanical and electrical parts needed except from the exhaust piping which is to be adapted according to the customers installation.

Mechanical system

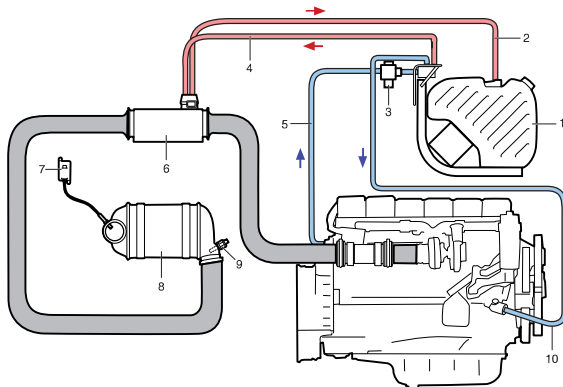

	Mechanical system	Standard	Optional
1	Reductant tank and pump module	38 l	60 l
2	Reductant fluid return line	2 m	3.5 m
3	Coolant valve	✓	–
4	Reductant pressure line	2 m	3.5 m
5	Coolant hose for tank and pump heating	–	–
6	Hydrolysis catalyst with reductant doser	✓	–
7	NO _x sensor with control unit	✓	–
8	SCR catalyst	✓	–
9	Temperature sensor	✓	–
10	Coolant hose, return from tank and pump heating	–	–

Electric system

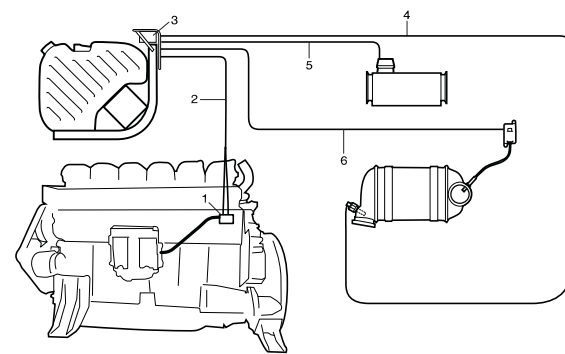

	Electric system	Standard	Optional
1	Customer interface, SCR system	✓	–
2	Pipe network between engine and SCR control unit	3 m	6 m
3	Electrical interface, SCR system	✓	–
4	Temperature sensor electrical cable	3 m	6 m
5	Reductant doser electrical cable	3 m	6 m
6	NO _x sensor electrical cable	3 m	6 m



SCR system

US Tier 4i, EU Stage IIIB

Reductant tank - 38 litres

Total volume: 50 litres

Filling volume: 38 litres

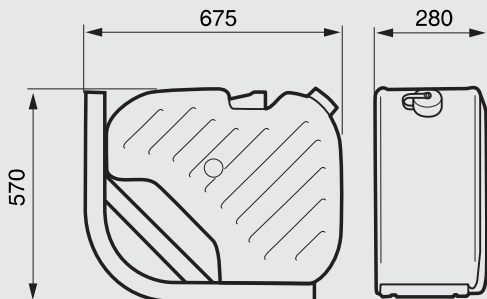

Reductant tank - 60 litres

Total volume: 70 litres

Filling volume: 60 litres

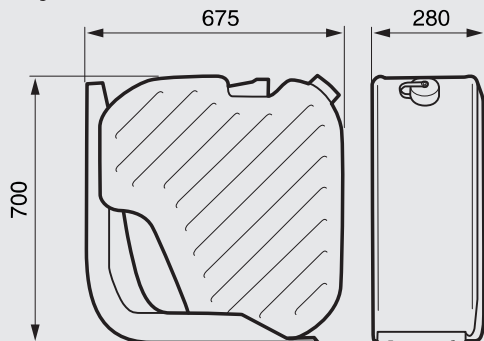

Hydrolysis catalyst with reductant doser

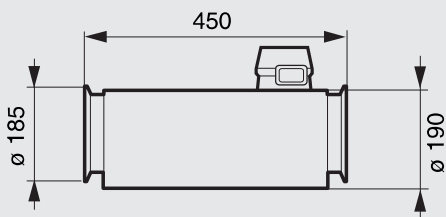

SCR catalyst

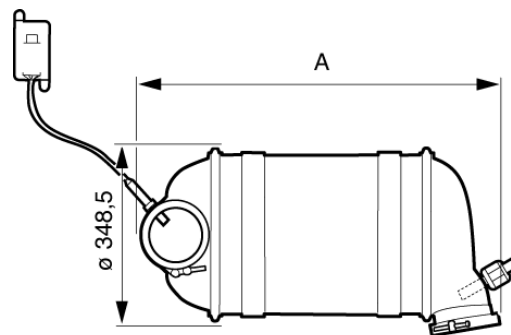

Engine	Power (kw)	Volume (litres)	Measure A (mm)
DC09	202-294	24	765
DC13	257-405	33	857
DC16	405-515	48	1060

SCR catalyst with silencer

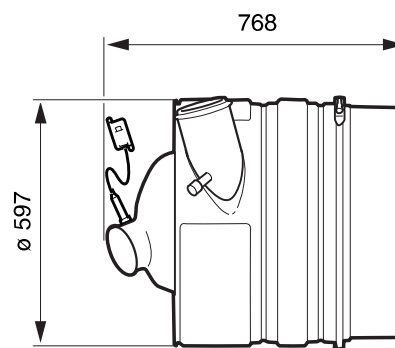

Engine	Power (kw)	Volume (litres)
DC09	202-294	33
DC13	257-405	33
DC16	Not available	



SCANIA

Scania Engines

SE 151 87 Södertälje, Sweden
 Telephone +46 8 553 810 00
 Telefax +46 8 553 829 93
 www.scania.com
 engines@scania.com